

# **ALGORITHMIC FIRE DETECTION**

## **CONTROL PANEL**

AE/SA-C8

INSTALLATION MANUAL

VERSION 1.2  
Abr/07



# INDEX

	PAGE
1. INTRODUCTION.....	5
1.1. PURPOSE OF THIS MANUAL.....	5
1.2. REMARKS.....	5
1.3. WARNINGS AND PRECAUTIONS .....	5
1.4. OFFICIAL APPROVAL.....	5
2. CONTENT. MATERIAL INCLUDED IN THE PACKAGE .....	7
2.1. PANEL VERIFICATION .....	7
2.2. LINE CONTROL CARDS .....	7
2.3. MATERIAL .....	7
3. INSTALLATION.....	9
3.1. PANEL LOCATION .....	9
3.1.1. DIMENSIONS AND SECURING POINTS .....	9
3.1.2. ANCHORING THE BOX.....	12
3.1.3. REMOVING THE MOTHER BOARD .....	14
3.1.4. REMOVING THE POWER SUPPLY UNIT.....	14
3.2. CONTROL PANEL PARTS .....	14
3.2.1. FRONT PANEL .....	15
3.2.2. MOTHER BOARD .....	15
3.2.3. AE/SA-CTL LINE CONTROL CARDS .....	15
3.2.4. POWER SUPPLY UNIT .....	15
3.2.5. EMERGENCY BATTERIES .....	15
3.3. CONNECTING THE EXTERNAL CIRCUITS .....	16
3.3.1. 230 Vac MAINS POWER SUPPLY .....	16
3.3.2. BATTERIES.....	18
3.3.3. 24V AUXILIARY POWER SUPPLY OUTPUT .....	19
3.4. REMOTE SWITCH-OFF .....	20
3.4.1. EVACUATION SIREN .....	20
3.4.2. GENERAL RELAYS .....	21
3.4.3. DAY/NIGHT OPERATING MODE .....	22
3.4.4. DETECTION LOOPS .....	22
3.4.5. RS-232 AND RS-485 COMMUNICATIONS PORTS.....	23
3.4.6. EARTH FAILURE MONITORING.....	24
4. RECOMMENDATIONS .....	25
5. PUTTING THE PANEL INTO OPERATION .....	27
5.1. AE/SA-CTL LINE CONTROL CARD .....	27
5.2. CPU DILSWITCH CONFIGURATION.....	29
5.3. PUTTING THE INSTALLATION INTO OPERATION .....	31
5.3.1. STARTING UP IN LOCAL MODE .....	32
5.3.2. PANEL CONTROL WITH PC START-UP SOFTWARE.....	33
5.4. INSTALLATION CONFIGURATION.....	34

6 .	CONSUMPTION (BATTERY CALCULATION) .....	35
6 . 1 .	BATTERY CALCULATION PROCEDURE.....	35
6 . 1 . 1 .	DURATION.....	35
6 . 1 . 2 .	CAPACITY CALCULATION .....	35
7 .	MAINTENANCE .....	37
7 . 1 . 1 .	PERIODIC OPERATIONS.....	37
7 . 1 . 2 .	USEFUL LIFE OF MAIN COMPONENTS .....	37
8 .	SPECIFICATIONS .....	39
9 .	INSTALLATION RECORD SHEET .....	43

## 1 . INTRODUCTION.

---

### 1 . 1 . PURPOSE OF THIS MANUAL

The purpose of this manual is to provide the user with full information about recommended procedures and technical details in order to carry out the installation and putting into operation of an AE/SA-C8 Algorithmic Fire Detection Control Panel.

The procedures described in this manual include notices and warnings of use to the user that adopts safe, methodical work practices during installation and putting into operation.

### 1 . 2 . REMARKS

- This manual is only valid for the connection and putting into operation of the **AE/SA-C8** Control Panel. For all other models, the corresponding manual should be consulted.
- The manufacturer reserves the right to change, modify or correct the information without any prior warning.

### 1 . 3 . WARNINGS AND PRECAUTIONS

 The installer of the Control Panel and all the other equipment forming the Fire detection System must be an authorised installer, trained in its operation and also conversant with the current applicable legislation.

Before connecting any piece of equipment, the power supply to the Control Panel must be switched off.

The user must read this manual and fully understand all its content before commencing any task related to the AE/SA-C8 Algorithmic Control Panel. If any doubts arise with respect to content of this manual, the supplier must be consulted before commencing the installation and putting into operation.

### 1 . 4 . OFFICIAL APPROVAL

The control panel has been designed in accordance with:

- The EN54-2 and EN54-4 standards for both mandatory functions and certain optional ones with requirements.
- Electromagnetic compatibility with European Community Directive EEC/89/336 and amendments EEC/92/31 and EEC/93/68.
- Compatibility with the European Low Voltage Directive EEC/73/23 and amendment EEC/93/68.

Some of the panel functions can be configured for enhanced effectiveness, improving equipment performance, but which are not contemplated by EN54, and their use would involve non-compliance with this standard.

When any type of connection or configuration is employed that does not comply with this standard, this must be indicated with a brief explanation of the requirements marked by the EN54 standard.

## 2 . CONTENT. MATERIAL INCLUDED IN THE PACKAGE

---

### 2 . 1 . PANEL VERIFICATION

It is important to perform a visual inspection, before commencing installation operations, in order to verify that the supplied equipment has not suffered any damage. If anything is noted, then the equipment **MUST NOT BE** installed and the supplier must be contacted.

### 2 . 2 . LINE CONTROL CARDS

There may be between one and four AE/SA-CTL line control cards connected to the panel depending on the installation.

These cards have to be configured by means of selector switches and located in the connectors on the mother board (see Section 6.2)

### 2 . 3 . MATERIAL

The packing box, which is located next to the panel contains the following material:

1. Installation Manual: this manual. Ae-man-810-0.0
2. User and Operating Manual: Ae-man-803-0.0
3. Cable Kit for emergency batteries.
4. Set of keys for the front panel access level selector.





## 3 . INSTALLATION

---

### 3 . 1 . PANEL LOCATION

The Control Panel must be installed in a suitable location, in a protected, monitored zone that meets the following requirements:

- The environmental operating temperature must remain between +5°C and +35°C.
- The relative humidity must lie between 5% and 90%.
- The panel should be mounted on a wall so that the screen can be clearly seen and the operating keys can be easily accessed. The height from the floor should be selected so that the screen is at eyelevel (approximately 1.5 metres).
- The panel must not be located in any location exposed to high levels of humidity.
- The panel must not be located in any location exposed to vibration or impacts.
- The panel must not be located in any location where access to the internal equipment and wiring connections is restricted.

For correct equipment operation, the recommended distances for achieving correct ventilation and preventing excessive equipment heating must be respected.

#### 3 . 1 . 1 . DIMENSIONS AND SECURING POINTS

The Control Panel is housed inside a metal cabinet measuring 520 mm high, 390 mm wide and 145 mm deep.

It is recommended that a free space of at least 100 mm is left around the entire box to ensure correct equipment ventilation.

The dimensions are shown in the following diagram:

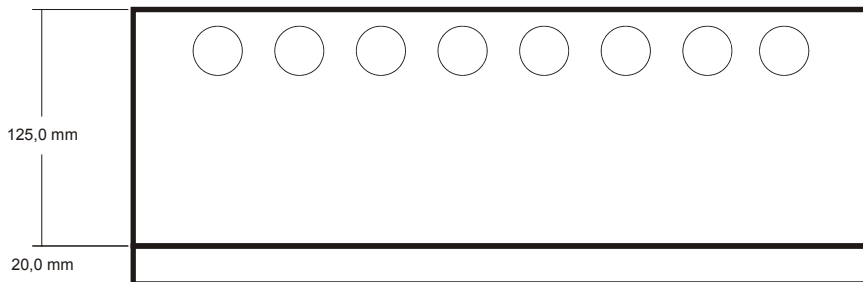
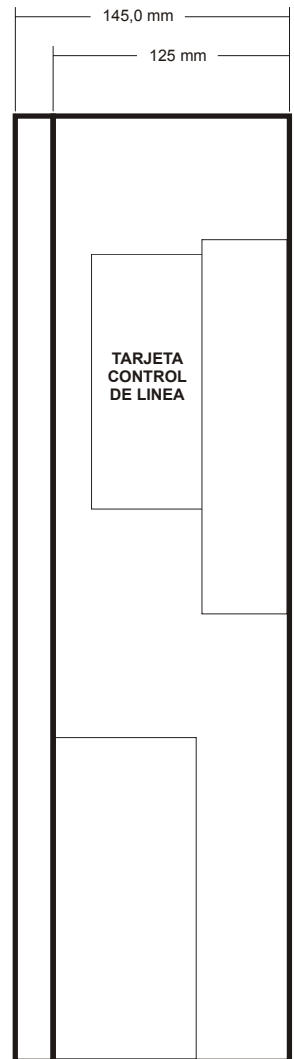
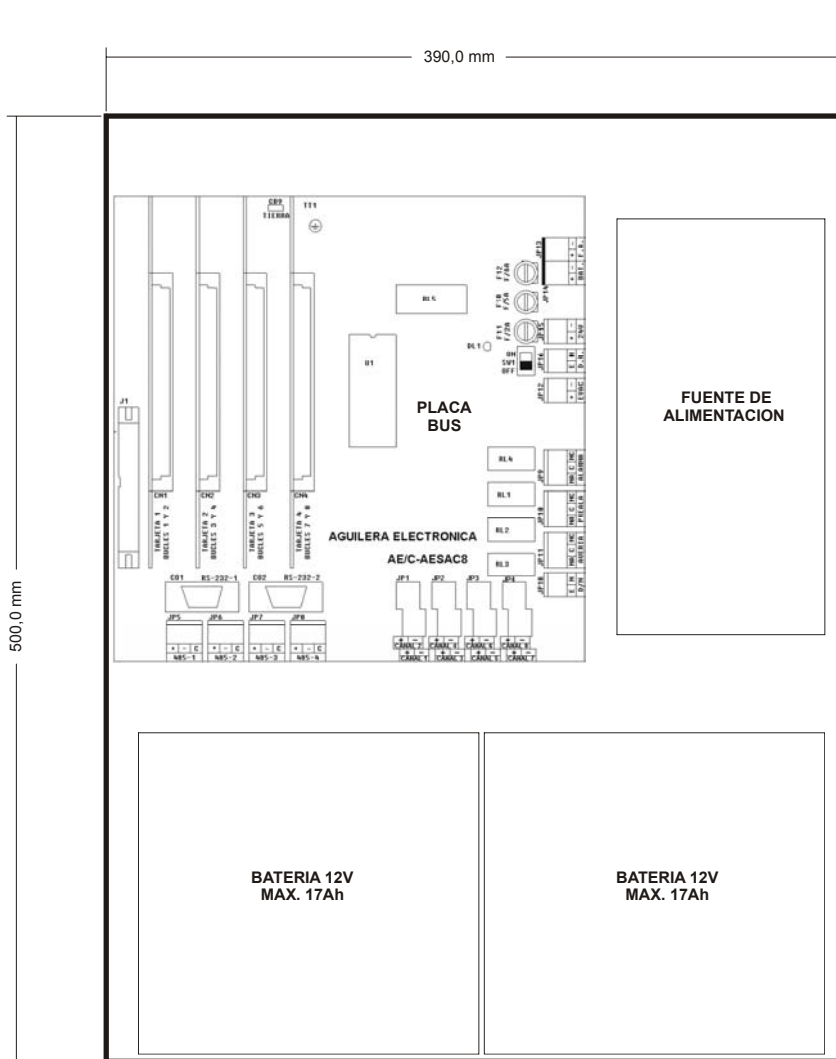
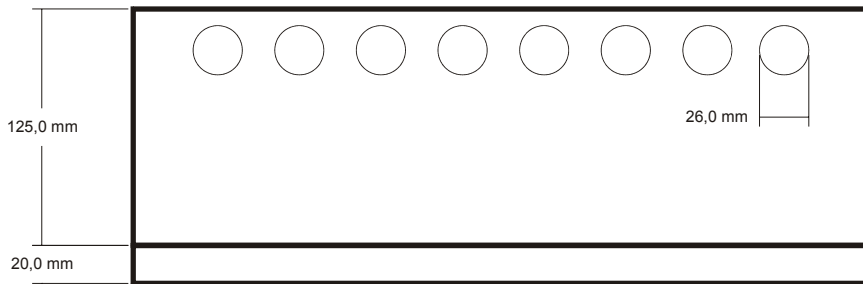



### 3 . 1 . 2 . ANCHORING THE BOX

**i** The AE/SA-C8 Control Panel can weigh over 225 kg with the batteries installed. When the box is secured to the wall suitable elements must be employed and the wall should be reinforced if necessary.

The necessary holes must be prepared for cable entry into the Control Panel:

- If this cable entry is to be at the top or bottom, the die-stamped holes can be opened by striking them with a suitable tool, taking care not to hit outside the dies-stamped area. Only those holes that are actually required should be opened.
- If cable entry is to be made at the back of the box, then the rear plate must be removed. This is accomplished by cutting off the side handles on the plate.

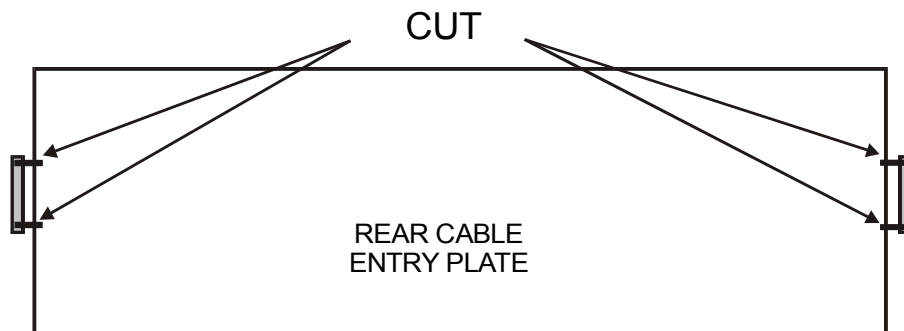

If any holes are required in the box, then the instructions in Section 3.1.3 for the removal of the printed circuit board from the mother board and 3.1.4 for the removal of the power supply should be followed to prevent them from being damaged.

**i** Once all holes have been made, all metal filings must be removed.

The box should be fastened to a suitable location on the wall, using the existing four 6-mm holes, two at the upper ends and two at the lower ends. The height at which the box is secured must make it possible to comfortably view the LCD and use the controls.

The following figure shows the box anchoring heights:

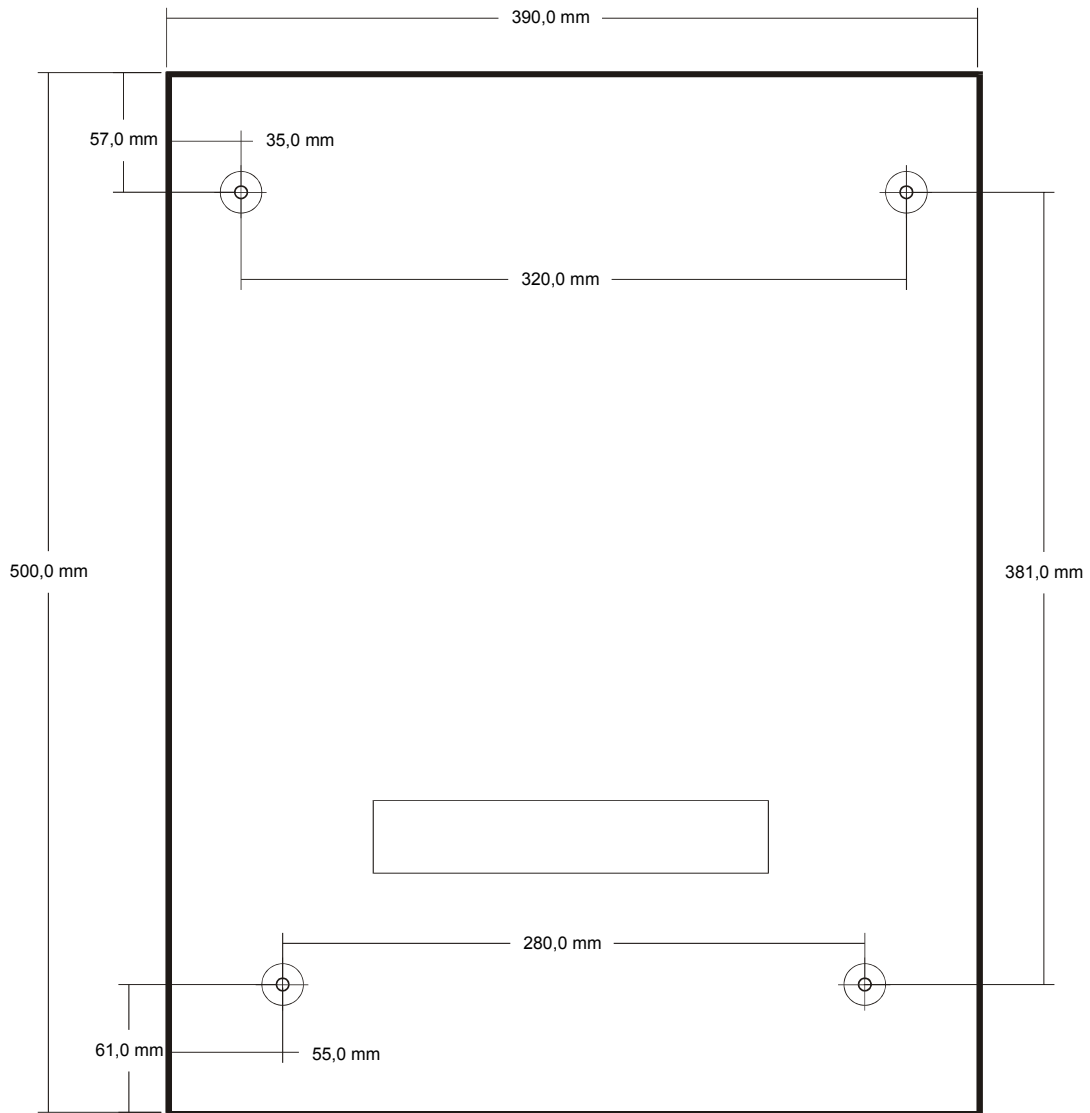

### 3 . 1 . 3 . REMOVING THE MOTHER BOARD

To remove the mother board, the line control card must be removed first (assuming they have already been connected). This cards is individually identified using a code set on the selector at the top and are associated with a specific connector on the mother board in function of the installation distribution, which means they must be returned to the same position and in the same order.

The mother board is secured to the box by eight anchoring points and one M4 screws with locking washers that guarantee a good earth connection for the printed circuit board.

The power supply and battery connectors are removable, whereas the rest of the installation wiring uses fixed terminal connections that have to be released.

To remove the mother board from the box, the mains power to the detection panel must be removed and the batteries disconnected in order to ensure that no electric power is available.

### 3 . 1 . 4 . REMOVING THE POWER SUPPLY UNIT

The power supply unit is fixed to a chassis inside the box using two anchoring points and two M4 screws with locking washers that guarantee a good earth connection.

To remove the power supply from the box, the mains power to the detection panel must be removed and the batteries disconnected in order to ensure that no electric power is available.

## 3 . 2 . CONTROL PANEL PARTS

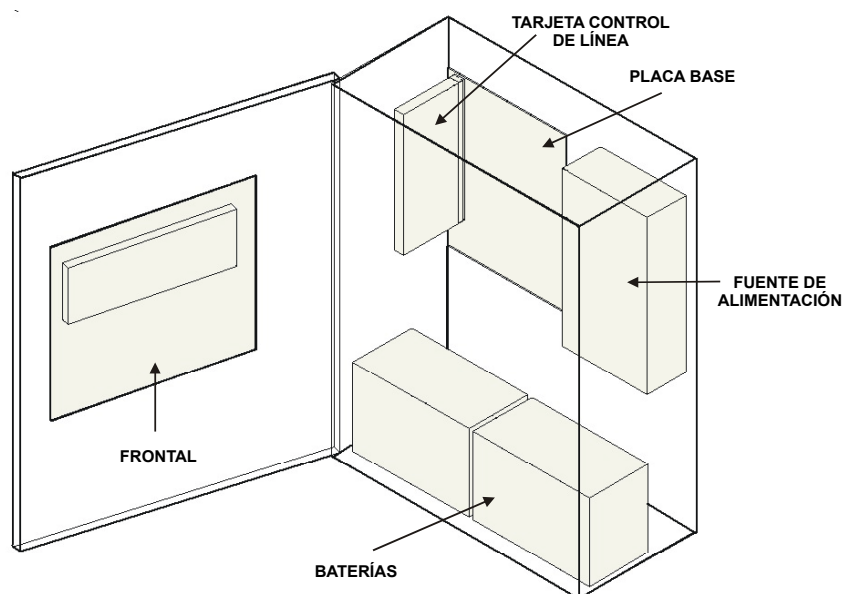

### 3 . 2 . 1 . FRONT PANEL

This is employed for system alarm display and control. It also includes the keypad and CPU.

### 3 . 2 . 2 . MOTHER BOARD

All the connections between the various Control Panel components and the rest of the installation are made via this circuit.

It consists of several parts:

- CPU connection.
- Voltage regulators, battery charger and fuses.
- Connector CN1 for the line control card.
- General relays.
- Protection fuses.
- Connection terminals for the installation wiring.
- RS-232 and RS-485 port connections.

### 3 . 2 . 3 . AE/SA-CTL LINE CONTROL CARDS

These are mounted on the mother board. They control the installation detection loops. Its card can control two detection loops, each with 125 components (detectors, pushbuttons, input modules, operation modules etc).

### 3 . 2 . 4 . POWER SUPPLY UNIT

This converts the 230 Vac mains power into 28 Vdc for powering the Control Panel and the rest of the installation.

### 3 . 2 . 5 . EMERGENCY BATTERIES

These will provide power to the installation in the case of a mains power failure.

### 3 . 3 . CONNECTING THE EXTERNAL CIRCUITS

The wiring must be inspected and tested before connecting the Control Panel and before connecting the terminals, ensuring that each wire is connected to its corresponding terminal in order to prevent damage to the equipment.

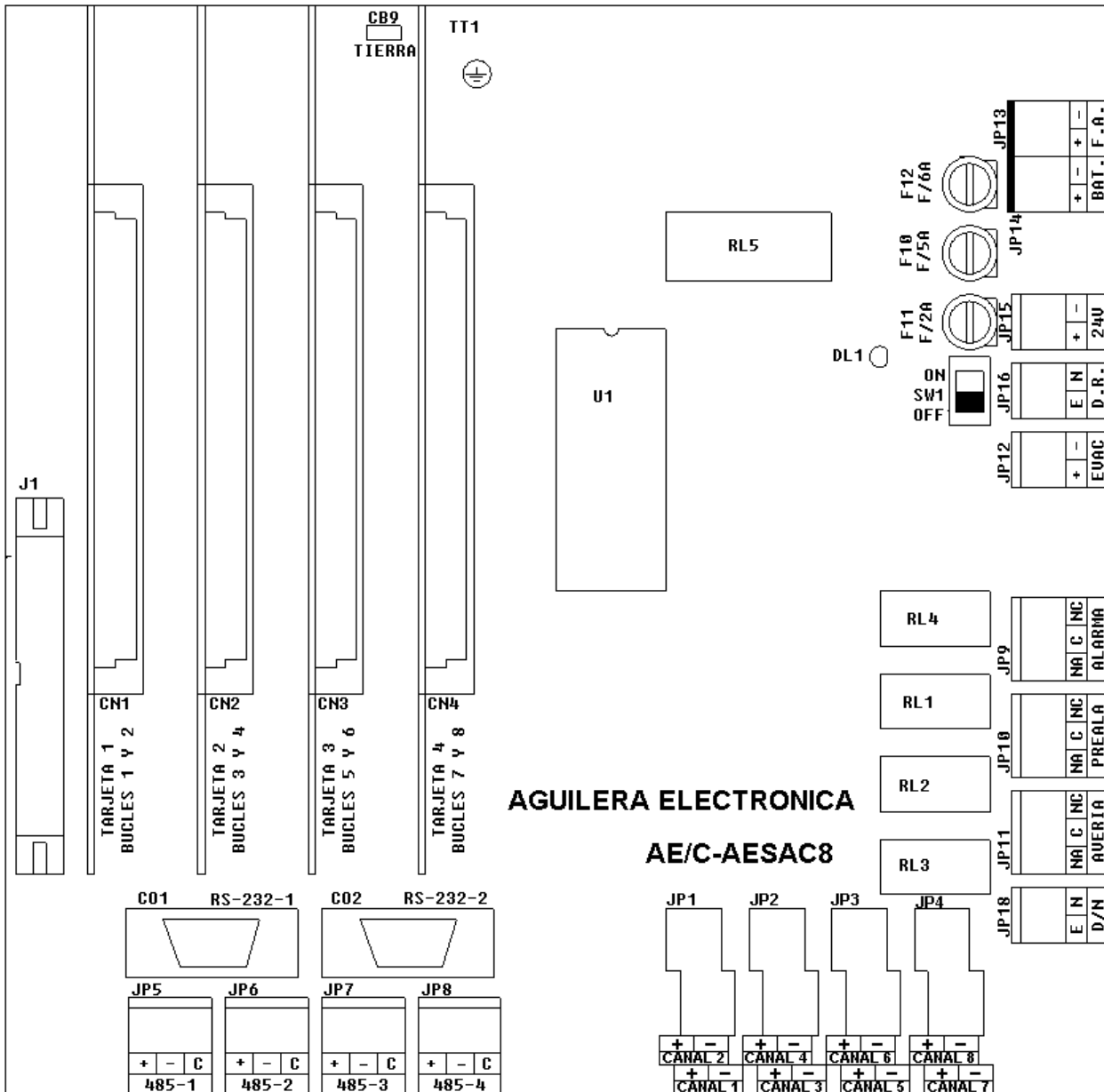

#### 3 . 3 . 1 . 230 Vac MAINS POWER SUPPLY

**i** Before making any connections, it must be verified that no electrical power is connected to any of the cable by isolating the associated mains electric power board.

The AE/SA-C8 Control Panel must be supplied at 230 Vac, 50Hz.



The 230 Vac conduit and wiring must physically separate from all other Control Panel wiring. The entry hole at the far right must be used for power supply wiring.

The supplied cable gland must be employed.

The connection should be made directly to the power supply unit in the following manner:

The power supply unit plastic protective cover should be lifted.

- The live wire (brown) must be connected to terminal L.
- The neutral wire (blue or black) must be connected to terminal N.
- The earth wire (yellow - green) should be connected to terminal T.

**i** Once all connections have been made, the protective terminal cover supplied with the power supply unit must be fitted.

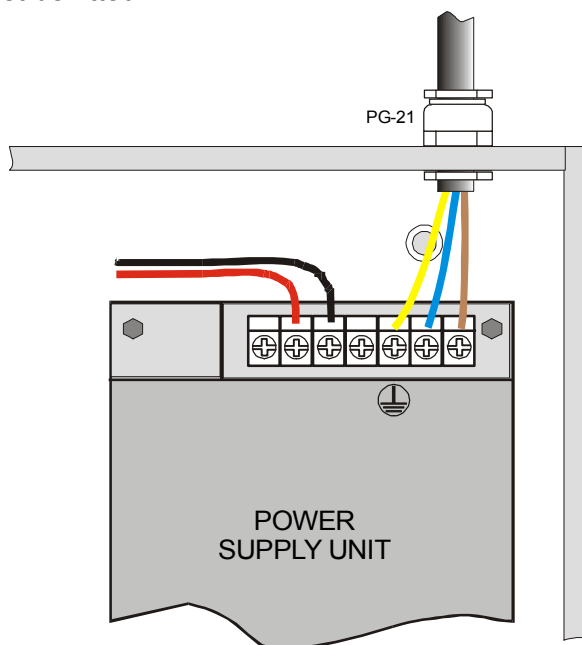

The fire detection control equipment must have an independent protection differential breaker with a 230 Vac / 5A or larger fuse. The power supply wiring section must be at least 0.75 mm<sup>2</sup>.

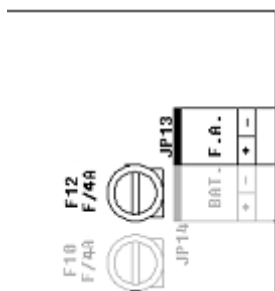

The power supply output is connected to the mother board by connector JP13, and protected by the 6A fuse F12.

### 3.3.2. BATTERIES

**i** The battery capacity must be calculated for the system charge conditions. See Section 6.

The Control Panel box can hold two 12volt batteries of up to 17Ah capacity.

The battery installation must be performed last, after all the installation wiring has been connected, since will facilitate access inside the box and to the mother board connectors.

The batteries must be installed in their reserved space, which must not be used for wiring or any auxiliary elements.

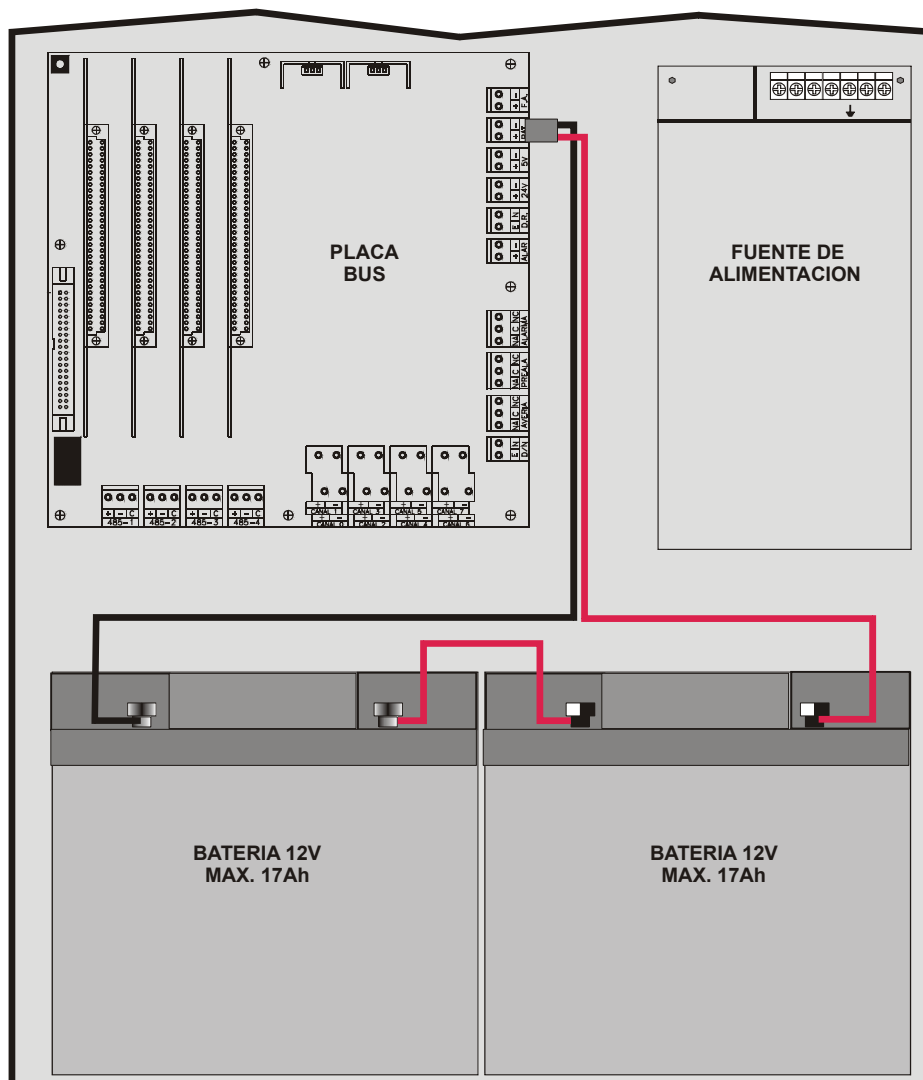

The box includes a battery connection cable, which is connected to the mother board. The red positive connector goes to the positive battery terminal 1 and the black negative connector goes to the negative battery terminal 2.

The batteries are connected in series and this requires that they be connected together with a jumper. The negative terminal of battery 1 should be connected to the positive terminal of battery 2 using the supplied short length of wire.

**i** Once the batteries have been connected each of the terminals must be covered using the protectors that are supplied with the cable.

The battery cable must not be connected to the mother board until both batteries are completely wired; this is to prevent any accidental short circuits or earth contact with any metal part of the box.

After all battery wiring has been completed, the polarised connector should be plugged into JP14.

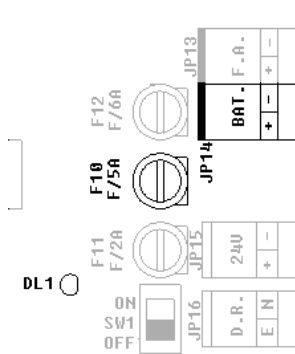

The batteries are protected with 5A fuse F10.

Yellow LED DL1 will light if the batteries are short-circuited or the charge current exceeds 1A.

### 3 . 3 . 3 . 24V AUXILIARY POWER SUPPLY OUTPUT

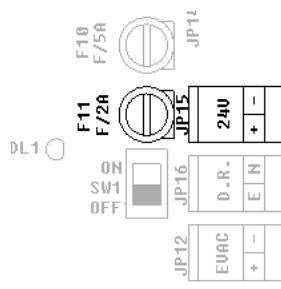

The equipment has a keyed auxiliary 24 Vdc output at connector JP15.

This output is protected by 2A fuse F11.

Before making the connection, it must be verified that the line is not short-circuited and that none of the protection diodes in relay coils and fire door retainers etc have their polarities inverted.

All polarities should be verified when making connections. The + and – poles must be connected to the corresponding terminals.

### 3 . 4 . REMOTE SWITCH-OFF

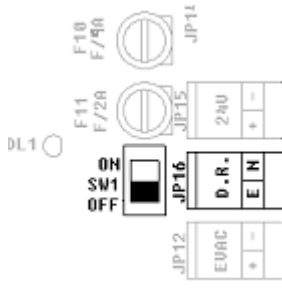

The equipment is fitted with a remote switch-off input in connector JP16, using a voltage-free contact.

Terminals E and N must be connected together to perform the remote switch-off operation.

The remote input and the main switch located on the mother board are connected in parallel, so that the equipment will remain off is either or both these switches are in the OFF position.

#### 3 . 4 . 1 . EVACUATION SIREN

The installation's evacuation sirens may be connected in two different ways:

- At the local Evacuation output.
- At the remote equipment connected to the detection loops.

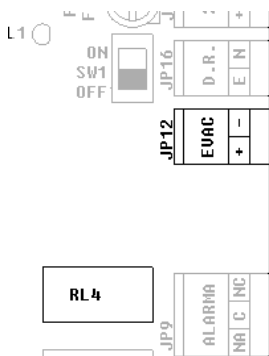

The local evacuation output connection is made on the mother board using two wires in connector JP12. The various evacuation sirens or bells are connected in parallel, with a 2K7 line termination resistor.

The sirens or bells must be polarised or have a series 1N4001 or similar diode connected.

Before making any connections, it must be verified that the line is not short-circuited and that there are no protection diodes with inverted polarity.

The maximum output current is limited to 1A.

The Installation Manual corresponding to the equipment employed contains a remote equipment wiring diagram.

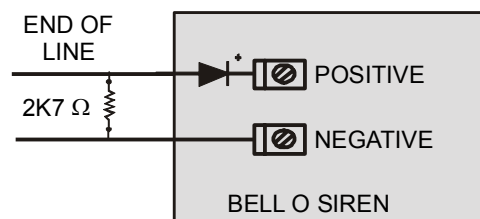

3.4.2. GENERAL RELAYS

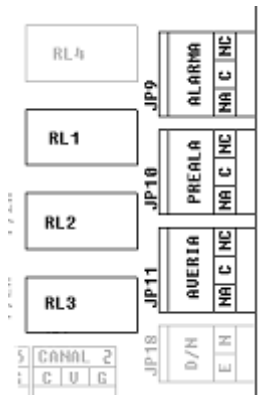

The AE/SA-C8 Control Panel includes three general relays with voltage-free output contacts:

- Alarm.
- Pre-alarm.
- Fault.

Each of these relays includes normally open **NA**, common **C** and normally closed **NC** contacts.

The relays are energised at the same time as the front panel pilot lamps come on, when the Control Panel is in one of these status conditions.

The fault relay is normally energised so that in the case of a control panel power failure, the fault signal will still be transmitted in accordance with EN54-2.

Relay energisation is monitored and the relevant information concerning any operational problem is sent to the panel.

**i** The relay contacts are limited to 2A at 30 Vdc. If larger currents or ac switching is required then the connection must be made via an independent relay.

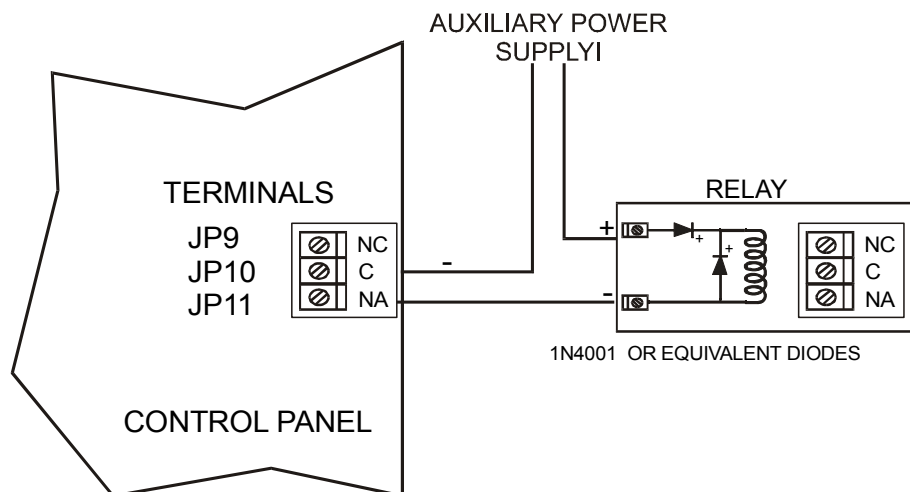

**3 . 4 . 3 . DAY/NIGHT OPERATING MODE**

The AE/SA-C8 control panel allows the operating mode to be remotely controlled using terminal JP18.

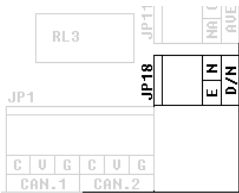

When the management of this remote input is enabled in the Installation Configuration Program, the panel will operate in “DAY” or “NIGHT” mode, in function of this input and will not permit the programming of changes in automatic modes.

If the input is open panel operation will be “NIGHT” and closed will be “DAY”.

**3 . 4 . 4 . DETECTION LOOPS**

The AE/SA series Control Panels can have a different number of detection loops depending on the number of installed line control cards.

Each line control card can control two detection loops and the mother board can hold one card.

Each detection loop can control up to 125 equipment units.

Card	Loops	Equipment
1	2	250
2	4	500
3	6	750
4	8	1000

Equipment distribution in the loops is determined by installation requirements.

**i** EN54-2 does not allow more than 512 equipment.

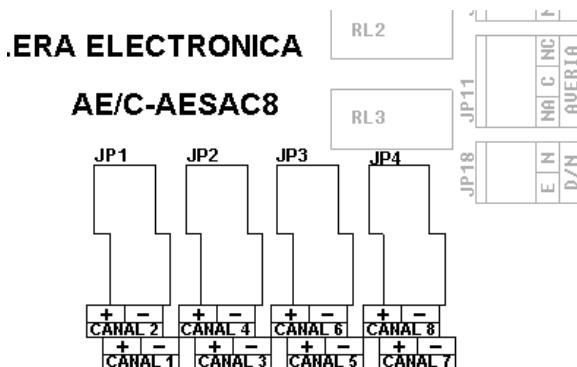

Connection is made with two wires, and can therefore carry the equipment power supply as well as the bidirectional communications.

The terminal assignment is given below:

- + +24 volts and communications
- - Common negative.

The wire sections for the loops are as follows:

POSITIVE: 1.5 mm<sup>2</sup>  
NEGATIVE: 1.5 mm<sup>2</sup>

It is recommended that officially approved cable be employed.

### 3 . 4 . 5 . RS-232 AND RS-485 COMMUNICATIONS PORTS

The AE/SA-C8 panel incorporates four serial ports for communications with other equipment or for integration with other systems, even when some of these have specific use.

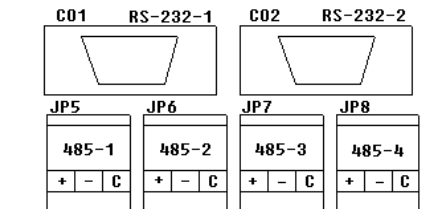

The COM1 and COM2 ports can be configured as RS-232 or RS-485 ports, although one of them must be configured as RS-232 at 9600 bps to permit configuration downloads. Normally, this same port can be simultaneously connected to a printer, leaving the port free for system integration.

Port type selection is done during installation configuration. When the panel is not configured, the configuration is RS-232 at 9600bps.

The connections of the RS-232 ports to a PC or printer are made by a null-modem cable with a DB-9 female connector, with the following pin assignment:

- Pin 2      RxD
- Pin 3      TxD
- Pin 5      Common negative.

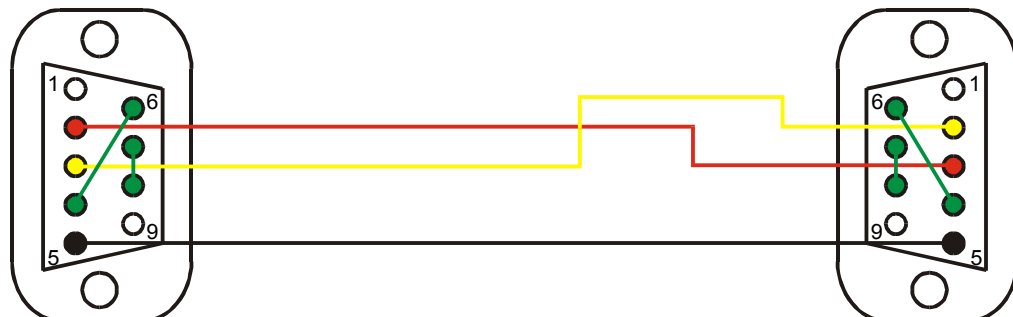

DB9 FEMALE CONNECTOR

DB9 FEMALE CONNECTOR

COM4 is RS-485 and is reserved for the AE2NET, which connects to other Control Panels, repeaters and control posts.

**i** Only available with the **AE/SA-C8RS** Control Panel model

The connections to the RS-485 ports have the following terminal assignments:

- +    Communications positive.
- -    Communications negative.
- C    Common.

### 3 . 4 . 6 . EARTH FAILURE MONITORING

Earth failure monitoring must be enabled during normal system operation. The connection of equipment to the RS-232 and RS-485 communications ports can cause an earth failure indication if such equipment has the communications negative connected to the same equipment's earth.

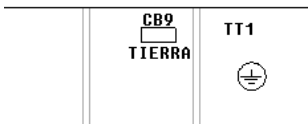

In order to avoid this problem, the panel includes switch CB9, to turn off earth failure monitoring.

**i** The switching off of the earth failure monitoring system involves non-compliance of EN54-2. If equipment incorporating isolated RS-232 or RS-485 ports, then this problem will not occur.



## 4 . RECOMMENDATIONS

---

- Recommended wire sections:      POSITIVE:                         1.5 mm<sup>2</sup>  
   NEGATIVE:                         1.5 mm<sup>2</sup>

AGUILERA ELECTRONICA has officially approved cable, with reference **AE/MANG2RF30**.

- When carrying out the installation, individual conduit should be employed and the modules and detectors must not be installed near sources of electromagnetic interference, such as fluorescent lamps, motors and contactors etc.
- Where installation close to sources of electromagnetic interference is unavoidable, it is recommended that screened cable is used for the installation.
- The power supply to the loop must be removed before connecting detectors or modules or carry out any other work on the line.
- It must be noted that the minimum module operating voltage is 18 Vdc. The last module in each loop must be checked. If, in spite of everything, excessive voltage drops occur, extra power supplies must be installed.
- If high current consumption components are installed, such as door retainers and sirens, then another power supply line could be employed to prevent voltage drops.
- All components with coils, such as door retainers and electro-valves etc, must be protected using diodes to prevent any undesired reverse voltages that could damage the Control Panel and cause interference to the communications.

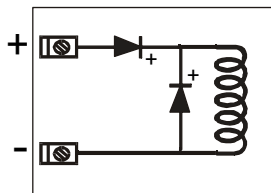

1N4001 OR EQUIVALENT DIODES

- Detectors should not be installed close to air conditioner outlets, because the stream of clean air would prevent any smoke produced by a fire from coming into contact with these detectors, which would reduce overall system efficiency. They should not be installed in domes or other enclosed spaces, which tend to form air chambers, especially in slow fires making it difficult for the smoke to reach the detectors.
- All analogue modules must be coded with their corresponding configuration numbers. This coding is carried out in binary using the DIP-switch on the module, with each being assigned a number from **1** to **125** as applicable. To facilitate this task for each piece of equipment, a table is included with each of the 125 DIP-switch possibilities.

- Before the module is connected to the analogue loop, **its correct coding must be verified**. If more than one piece of equipment has the same number on the same loop, system operation will not be correct.
- Each analogue point is configured with the name of the controlled equipment, the type of operation and the installation location.
- The exit points are programmed so that they operate with the change of parameters of one or more points and are configured with the name of the operation they perform.
- The status of alarms, faults, disabled and other events is determined by the Control Panel by comparing the received parameters with those established for each equipment unit.
- The power supply to the modules in the installation is taken from the loop (+) positive and (-) negative, and may even be power other equipment that they control, door retainers, infrared and bells etc, provided that the consumption of each loop is taken into account in order to plan for wire sections and total installation consumption. If thus turns out to higher or equal to that of the Control Panel power supply, then extra power supplies must be installed in the loops with highest consumption.

## 5 . PUTTING THE PANEL INTO OPERATION

### 5 . 1 . AE/SA-CTL LINE CONTROL CARD

The AE/SA-CTL line control card must be inserted into the mother board connectors once the panel has been fully connected.

Each control card can control two loops, each with a maximum of 125 equipment units.

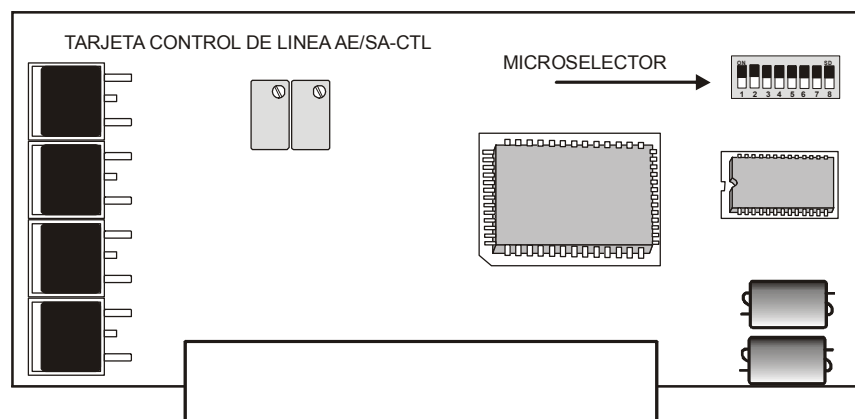

The line control card must have the following code set in the DIL-switch unit:

Of the eight switches, only the first two are used to determine the cards address on the panel.

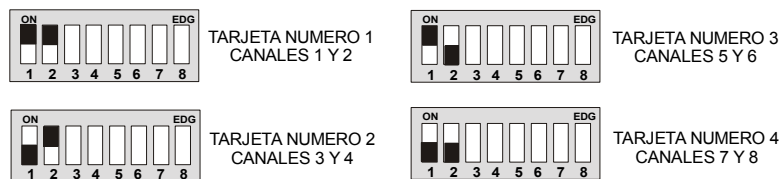

Once the card has been configured, it should be connected to the bus as shown below:

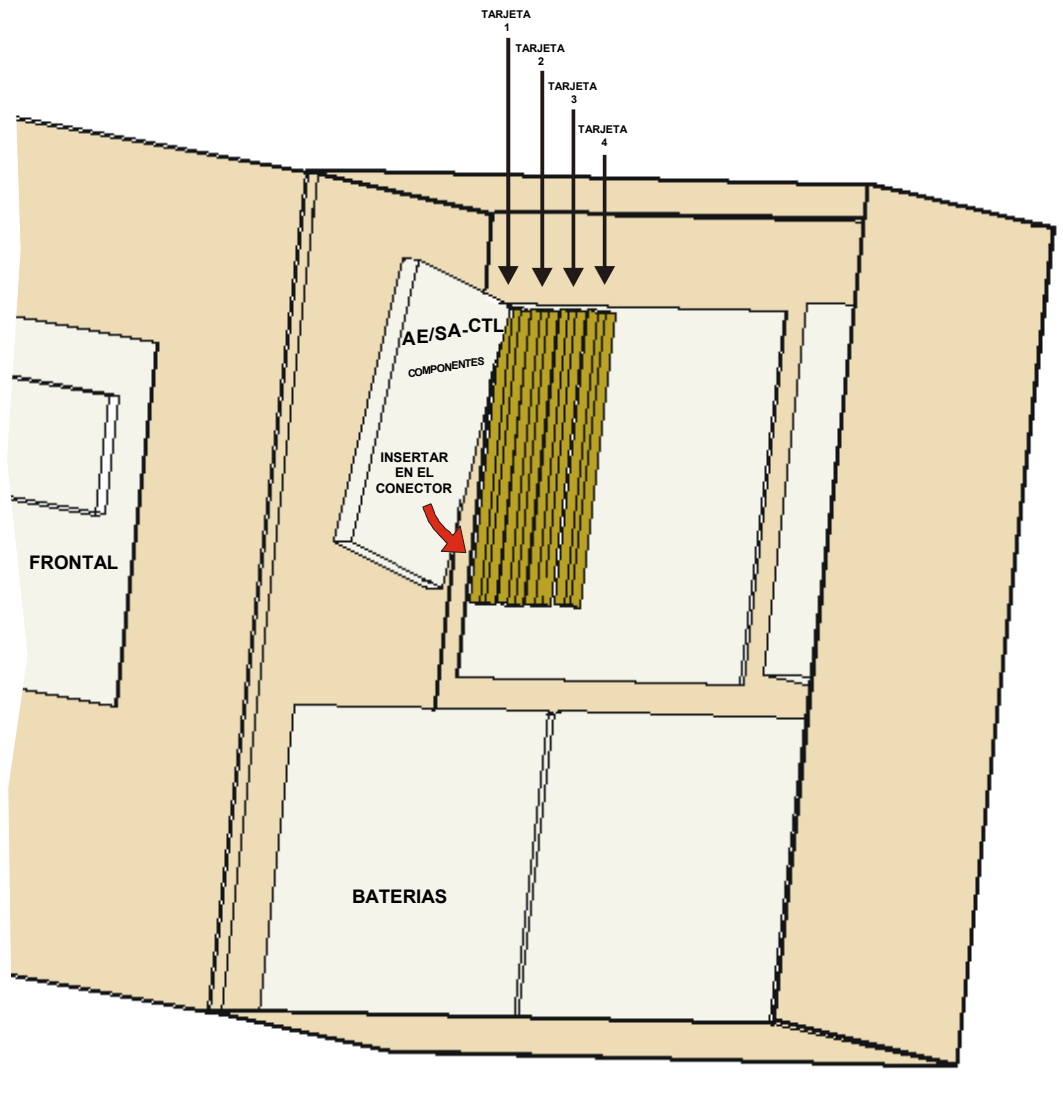

**i** Before making any connections the Control Panel must be switched off by setting SW1 to the OFF position.

Insert the card into its responding slot, with the component side to the right. The keyed connector prevents the card from being inserted incorrectly.

## 5 . 2 . CPU DILSWITCH CONFIGURATION

The Algorithmic System AE/SA-C8 Control Panel is fitted with a DIL-switch with eight individual switches, which is used to configure certain operational aspects.

In general and except where specifically indicated otherwise, the DIL-switch positions should only be changed with the Control Panel switched off. When the unit is switched on again any modifications that are made will then take effect.

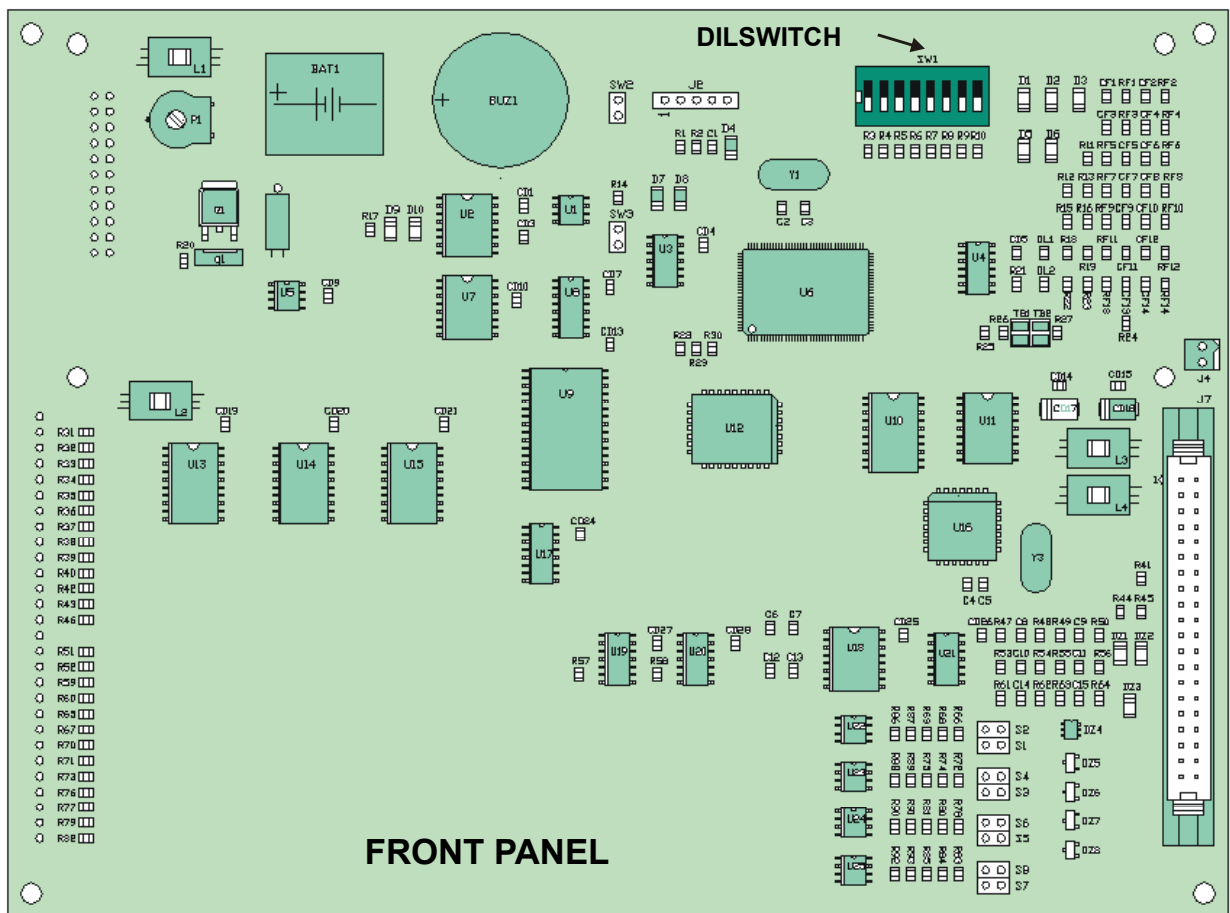

### Positions 1-5

These five switches determine the panel network address.

The address is set in binary code. The OFF position is a '1' and the ON is a '0'.

The valid address range is from 1 to 31 inclusive.

### Positions 6-7

AE2NET bitrate.

6	7	Bitrate
ON	ON	312 Kbps
OFF	ON	156 Kbps
ON	OFF	78 Kbps
OFF	OFF	39 Kbps

**i** All the equipments in the same AE2NET must have the same bitrate configured.

### **Position 8**

This switch is used to force a complete deletion of the Control Panel's configuration. If the Control Panel is switched on with this switch in the OFF position, a message will be displayed on the screen warning that the configuration is about to be deleted and requesting confirmation from the user.

- If the user confirms the operation by pressing the <YES> key, the Control Panel will delete the stored configuration and commences operation without any configuration.
- If the user cancels the operation by pressing the <NOT> key, the Control Panel will continue to operate normally using the stored configuration, assuming that one exists.

**i** The Control Panel will wait for user confirmation one way or the other indefinitely. The Control Panel will not continue until the user either confirms or deletes the configuration deletion operation.

The actual confirmation message will recommend that the user return switch 8 to its normal ON position before continuing, otherwise, it will perform the same operation of requesting confirmation the next time it is switched on, running the risk of erroneously confirming an undesired configuration deletion operation.

### 5 . 3 . PUTTING THE INSTALLATION INTO OPERATION

Once the AE/SA-C8 panel is powered from the mains and/or battery supply and is switched on by setting the main switch to the ON position, the following screen will be displayed:

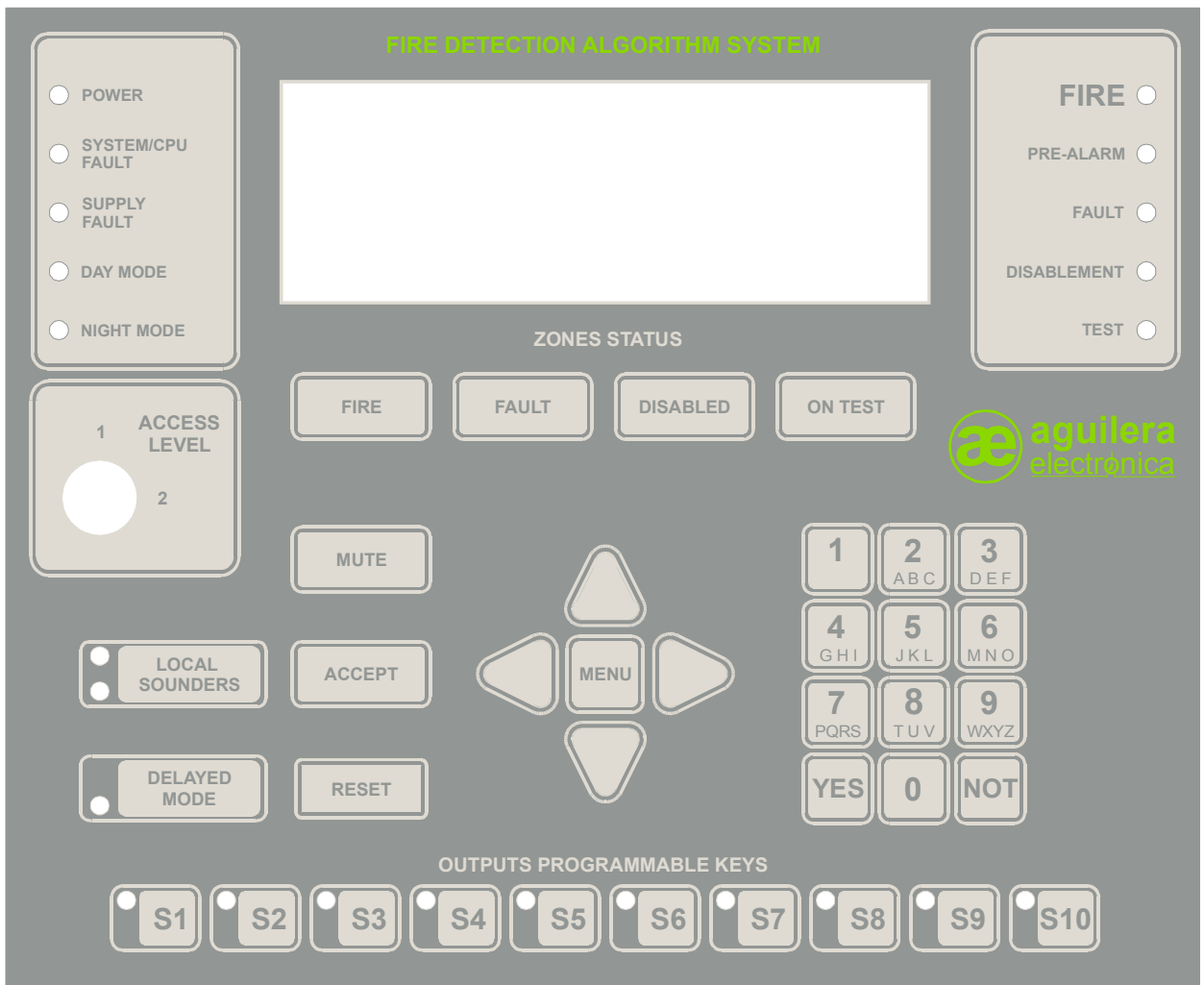

While the panel is not configured with the actual installation information, it will display this message on the screen, indicating date, time, panel model and software version.

Pressing the “MENU” key on the front panel will display the menu with the available options.

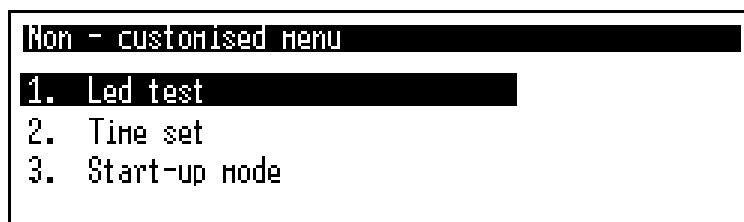

The menu options are selected with the arrow keys and confirmed using the “YES” key or by pressing the number associated with the option.

Selecting option “1. LED test” will turn on all the LED pilot lamps on the front panel for two seconds.

Option “2. Time set” permits adjustment of the panel’s real-time clock date and time. It is very important that these two parameters are correct because incidents are stored in the log file with the date and time set by the panel when they are produced.

Option “3. Start-up mode” allows the installation to be started up in local mode.

5.3.1. STARTING UP IN LOCAL MODE

When local start-up mode is entered, confirmation is requested by means of the following screen:



Once confirmed, the information for the various recognised equipment components is displayed in the following format:

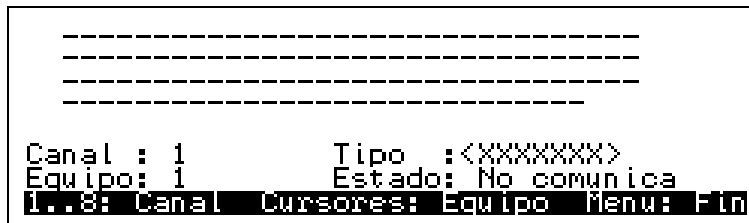

The first four lines contain one character for each possible equipment unit detected in the channel (for a possible total of 125).

The displayed character indicates the equipment status as described below:

- '-' A dash indicates that the associated equipment is not currently communicating.
- 'R' The equipment is communicating correctly and in standby.
- 'A' The equipment is communicating correctly and in an alarm condition.
- 'V' The equipment is communicating correctly and in a fault condition.



The following lines contain detailed information about the currently selected equipment:

- Canal (Channel)** Indicates the current channel number.  
The actual channel selection is carried out using the numerical keys.
- Equip.** Indicates the current equipment number. The possible range is [1..125].  
The actual equipment selection is carried out using the four cursor keys.
- Tipo (Type)** This is the commercial reference for the current equipment unit.  
If no equipment at the current address has responded, then '<XXXXXXX>' will be displayed
- Estado (Status)** This is an expanded form of the last known status of the current equipment as indicated by the previously described character. The possibilities are as follows: 'Not communicating', 'Standby', 'Alarm' and 'Fault'.

The diagram below is an example of a channel with functioning equipment:

```

RRRRRRRRRRRRRRRRRRUUUUUUUUUUUUUUUUUU
RR-RR-UUUUUUUUUUUUUUUUUUUUUUUUUUUUU-
-----
Canal : 1           Tipo : AE/94-OPA
Equipo: 15          Estado: Reposo
I..8: Canal  Cursores: Equipo  Menu: Fin
    
```

Pressing the "Menu" key will exit the start-up operating mode, but first requesting confirmation.

### 5 . 3 . 2 . PANEL CONTROL WITH PC START-UP SOFTWARE

It is possible to access panel control by means of the AGE41 Start-up software and via any of the RS-232 serial ports and a null-modem cable in order to carry out installation start-up from a computer.

Much more information is displayed than when in local mode and this permits:

- An indication of the analogue detector level.
- The individual status of each equipment point.
- Output operation, including detector operation indicators.
- Event log listings.
- Data acquisition for configuration purposes etc.

## 5 . 4 . INSTALLATION CONFIGURATION

It is essential that the panel be configured with installation information for the installation to be fully operational.

Only then will all panel functions be accessible and all connected equipment units be recognised and report all incidents that are produced within the installation.

The “**AGE42** installation configuration” software is used to define all installation parameters, with the various components that make it up and their operation. Once configuration programming has been verified, it can be transmitted to the panel over one of the RS-232 ports or via the AE2NET network.

The following information screen will be displayed when the panel is fully configured and the entire installation is in standby:



Both the logo and the installation name can be customised.

 The installation will not be operational while the panel is not configured.

## 6 . CONSUMPTION (BATTERY CALCULATION)

The battery capacity must permit autonomous operation during at least 24 hours in standby and half an hour under alarm conditions.

The Control Panel includes a PSU that can provide a maximum current of 4.5A. It should be checked that the total consumption in standby and alarm does not exceed this current limit.

If the necessary current exceeds that supplied by the Control Panel, then it will be necessary to provide one or more additional power supplies.

**i** See the battery useful life specifications in Section 7.1.2.

### 6 . 1 . BATTERY CALCULATION PROCEDURE

The UNE regulations require that the installation be equipped with a double power supply, which is normally resolved by directly powering the installation from the buildings mains power supply and employing a set of batteries, connected to a Control Panel charger, as standby power, which enters operation in the case of a mains power failure.

#### 6 . 1 . 1 . DURATION

According to UNE 23007/14:1996, the emergency power supply must be able to supply power in accordance with the requirements of Table 4

CONDITIONS	STANDBY	ALARM
Always	72 hours	30 min.
There is a local or remote repair, that undertakes to carry out repairs within 24 hours	24 hours	30 min.
There are local personnel, spares and an emergency generator	4 hours	30 min.

#### 6 . 1 . 2 . CAPACITY CALCULATION

The following formula is used for this calculation:

$$C_{\min} = ( A1 \times t1 + A2 \times t2) \text{ amperes/hour,}$$

where:

- t1 and t2 are the operating times in standby and alarm respectively.
- A1 and A2 are the system consumptions in standby and alarm.

An extra 25% should be taken into account to cover battery ageing, so that the total capacity is:

$$1.25 \times C_{\min}.$$

A1 is determined by summing the consumption of all detection system components, and A2 by calculating the consumption under alarm conditions of all components that intervene simultaneously.

	STANDBY CONSUMPTION				ALARM CONSUMPTION				
	Units	Unitary (mA)		Total		Unitary (mA)		Total	
	Uds.	mA	Total	mA	Total	mA	Total	mA	Total
AE/SA-C8 C.P.U.		125		175					
AE/SA-CTL Tarjeta de Control de Línea		30		30					

<b>Equipos Algorítmicos</b>									
	Uds.	mA	Total	mA	Total	mA	Total	mA	Total
AE/SA-TV Detector Térmico		1,1		3,6					
AE/SA-OP Detector Óptico		1,7		4,2					
AE/SA-OPT Detector Óptico-Térmico		1,7		4,2					
AE/SA-TZ Detector Térmico con Zumbador		1,1		20					
AE/SA-OPZ Detector Óptico con Zumbador		1,7		20					
AE/SA-OTZ Det. Óptico-Térmico con Zumb.		1,7		20					
AE/SA-P Pulsador		1,0		3,8					
AE/SA-M Módulo Máster		1,0		1,3		17		44	
AE/SA-MDL Módulo Máster		1,0		1,3		17		44	
AE/SA-MC5 Módulo Máster		1,0		1,3		17		44	
AE/SA-2E Módulo 2 Entradas Digitales		1,13		1,2					
AE/SA-8E Módulo 8 Entradas Digitales		1,25		1,3					
AE/SA-2SV Módulo 2 Salidas Vigiladas		1,1		1,7		13		28	
AE/SA-2S Módulo 2 Salidas Relé		2,7		2,8					
AE/SA-SE Módulo de Maniobra con Confirmación		1,85		1,9					
AE/SA-32S Módulo de 32 Salidas		1,02		21,7					
AE/SA-SIF Sirena Interior con Foco		1,0		1,3		0		60	
AE/SA-PX Panel de Extinción		1,25		1,3					
AE/SA-IFA Interface Fuente de Alimentación		1,25		1,3					

<b>Equipos auxiliares</b>									
	Uds.	mA	Total	mA	Total	mA	Total	mA	Total
AE/V-B6						0		30	
AE/V-SB						0		180	
AE/V-SF						0		360	
AE/V-AS						0		20	
AE/V-ASF						0		45	
AE/V-AF						0		300	
AE/V-R2435						60		0	
AE/V-R2435S						60		0	
AE/V-R2440						85		0	
AE/V-R2440S						85		0	
AE/V-R2460						70		0	
AE/V-R2460S						70		0	
AE/V-RP						0		95	
AE/V-RS						0		65	
AE/V-RSL						0		35	

**TOTAL**
**A1<sub>1</sub>**  **A2<sub>1</sub>**  **A1<sub>2</sub>**  **A2<sub>2</sub>**

## 7 . MAINTENANCE

---

A logbook should be prepared in accordance with the recommendations of EN54 Part 14. This book must be used and updated in order to record any events as described below.

### 7 . 1 . 1 . PERIODIC OPERATIONS

In order to ensure that the system is fully operational and to comply with the requirements of EN54 Part14, the following maintenance recommendations should be followed on a periodic basis:

- Daily. Verify that the panel indicate normal operation. If any faults are displayed check that they have been recorded in the log book and that all necessary action has been taken, for example, notifying the maintenance company.
- Weekly. Check a minimum of one sensor or pushbutton to verify correct operation of the panel and acoustic alarms. Check different a zone, and if possible an equipment unit each week. Maintain a log of the equipment and zone checked each week. Record and notify all problems.
- Three-monthly. The person responsible for maintenance should ensure that fully qualified personnel check the system on a three-monthly basis. The following operations must be carried out:
  - Check the logbook entries and the corresponding action taken.
  - Check the batteries under standby conditions and the charger voltage.
  - Check at least one equipment unit in each zone in order to verify panel functions.
  - Check operation of the acoustic alarms and any connections to a remote Control Panel or central station etc.
  - Perform a visual inspection of the installation in order to check for possible alterations or obstructions and prepare a test certificate.
- Annually. The person responsible for maintenance should ensure that, in addition to the three-monthly checks, each system equipment unit is checked, together with a visual inspection of all wiring and equipment.

### 7 . 1 . 2 . USEFUL LIFE OF MAIN COMPONENTS

The batteries must be replaced at least every four years.

The batteries must be disposed of by strictly following the manufacturer's recommendations and local regulations.



## 8 . SPECIFICATIONS

---

### AE/SA-C8 Control Panel specifications

#### Cabinet:

- Dimensions:
 

Width:	390 mm.
Height:	500 mm.
Depth:	145 mm.
- Material: Rolled plate AP 011
- Colour: RAL9002

#### Weight:

- Without batteries 9.5 kg
- With two 12V/17Ah batteries 22 kg

#### Environmental operating ranges:

- Temperature 0° to 49°C
- Relative humidity 85% without condensation.

#### Power supply:

- Mains power supply voltage 230 Vac at 50Hz
- Maximum input power: 150W
- Power supply voltage: 28Vdc
- Maximum input current 4.5 A
- Protection Fuse 5A
- Recommended cable: H05 VV-F, 3 x 1.5mm<sup>2</sup>

#### Batteries:

- Battery type: Sealed lead-acid rechargeable.
- Cabinet battery capacity: Two batteries, 12V/17Ah
- Battery charger voltage: 27.6 Vdc
- Maximum battery charger current: 1A
- Protection Fuse, 6A (for battery operation)

#### Auxiliary power supply output:

- Voltage 27.2 Vdc
- Maximum auxiliary output current: 2A
- Protection Fuse, 2A

#### Analogue detection loop:

- Wiring 2 x 1.5mm.
- Loop power supply voltage: 27.2 Vdc
- Maximum loop current 0.54A
- Protection PTC 2A

**Indicators:**

- Graphic display: 240 x 64 pixels, backlit
- Pilot lamps:
  - Service
  - System fault
  - Power supply fault
  - Day mode
  - Night mode
  - Pre-alarm
  - Alarm
  - Fault
  - Switch-off
  - Test
  - Local evacuation (Alarm and fault)
  - Delay
  - Operation sequences (10 pilot lamps)
  - Continuous under alarm conditions
  - Intermittent under fault conditions
- Acoustic alarm

**Operational keys**

- Zone status alarm, fault, switch-off, test.
- Numeric keypad 0...9 keys, Yes, No.
- Cursors up, down, left, right, menu.
- Access level 1 functions local evacuation, delay
- Access level 12 functions mute buzzer, reset, rearm
- Operation sequences 10 keys, configurable

**Capacity:**

- Number of analogue loops: 2 to 8 Loops
- Number of AE/SA-CTL analogue cards 1 to 4 (2 loops per card)
- Number of equip. units per analogue loop: 125 maximum
- Total number of equip. units in Control Panel: 1000 equip. units
- Total number of points in installation 3,000 points
- Total number of sectors in Control Panel 250 sectors
- Number of zones per sector 125 zones
- Total number of zones in Control Panel 1,024 zones
- Maximum analogue loop distance 1,200 m
- Storage Non-volatile flash memory.

**Customisable texts**

- Zones 32 characters
- Sectors 32 characters
- Operation sequences 32 characters
- Risks 10 characters
- Incident or event causes 16 characters
- Customisable logo text 25 characters
- Customisable logo graphic 144 x 56 pixels, 2 colours, BMP format
- Node name (Control Panel network) 10 characters



**Incident log**

- Memory type
- Number of stored incidents
- Incident date and time
- Display
- Incident search by date

Non-volatile RAM  
 > 4,000 incidents  
 Real time clock  
 Screen or printer  
 Complete  
 Alarms  
 Faults  
 Switch off  
 Tests  
 Messages

**Access levels (according to EN54-2):**

- Level 1
- Level 2
- Level 3
- Active access level time

Free access  
 Key or user access code.  
 User access code  
 60s, configurable.

**Operations**

- No of installation operation sequences
- No of operations per sequence
- No of trip sequence conditions
- No of sub-conditions for each condition
- Possible sequence actions

240 sequences  
 250 operations  
 250 conditions  
 32 sub-conditions  
 Activate / reset outputs  
 Activate / reset sequences  
 Rearm, Reset and Control Panel Mute

**General relays:**

- Alarm relay
- Pre-alarm relay
- Fault relay

Voltage-free NC, C and NO contacts  
 Voltage-free NC, C and NO contacts  
 Voltage-free NC, C and NO contacts  
 energised in standby according to EN54-2

**General evacuation**

- Output voltage
- Supervision
- Protection

standby -7.2 Vdc (may vary with load)  
 energised 27.2 Vdc  
 monitored with the 2K7 line termination  
 resistor.  
 PTC, 1.1A

**Remote operation inputs:**

- Switch off
- Operating mode

Remote Control Panel switch off.  
 Closed contact operation.  
 Day/Night, open/closed contact operation  
 configurable.

**Communications ports**

- Port 1 RS-232 or RS-485 configurable.
- Port 2 RS-232 or RS-485 Configurable.
- Port 3 RS-485 for internal use, communications with AE/SA-CTL cards.
- Port 4 RS-485 for use with AE2NET.

**Printer**

- Configurable.
- Connection with serial dot-matrix printer to ports 1 or 2 configured as RS-232.
- Time can be printed as operational test.
- Configuration
  - Speed: 2,400, 4,800, 9,600 or 19,200 bauds.
  - Number of bits: 8
  - Parity: none
  - Stop bits: 1

## 9 . INSTALLATION RECORD SHEET

---

DATE: \_\_\_\_\_

NAME (OWNER): \_\_\_\_\_

ADDRESS: \_\_\_\_\_

TELEPHONE: \_\_\_\_\_

PERSON RESPONSIBLE: \_\_\_\_\_ DATE: \_\_\_\_\_

PERSON RESPONSIBLE: \_\_\_\_\_ DATE: \_\_\_\_\_

PERSON RESPONSIBLE: \_\_\_\_\_ DATE: \_\_\_\_\_

PERSON RESPONSIBLE: \_\_\_\_\_ DATE: \_\_\_\_\_

INSTALLATION COMPANY: \_\_\_\_\_

ENGINEER RESPONSIBLE: \_\_\_\_\_

TELEPHONE: \_\_\_\_\_

MAINTENANCE COMPANY: \_\_\_\_\_

MAINTENANCE CONTRACT NUMBER: \_\_\_\_\_

VALID UNTIL: \_\_\_\_\_

**INCIDENTS LOG**

DATE	HOUR	INCIDENT	ACTION TAKEN	SIGNATURE





**YOUR NEAREST POINT OF ASSISTANCE AND SUPPLY**

**CENTRAL OFFICE**

C/ Julián Camarillo, 26 – 2ª Planta – 28037 Madrid  
Tel: 91 754 55 11

**GAS PROCESSING PLANT**

Av. Alfonso Peña Boeuf, 6. Pol. Ind. Fin de Semana – 28022 Madrid  
Tel: 91 754 55 11

**NORTHEAST OFFICE**

C/ Rafael de Casanovas, 7 y 9 – SANT ADRIA DEL BESOS – 08930 Barcelona  
Tel: 93 381 08 04

**EAST OFFICE**

Tel: 628 92 70 56

**NORTHWEST OFFICE**

C/ José Luis Bugallal Marchesi, 9 – 15008 – A Coruña  
Tel: 98 114 02 42

**SOUTH OFFICE**

Edificio METROPOL 3 – C/ Industria, 5 3ª Planta Mod.17  
Parque Industrial y de Servicios del Aljarafe (P.I.S.A.) – 41927 – Mairena del Aljarafe – Seville  
Tel: 95 465 65 88

**CANARIES OFFICE**

C/ Sao Paulo, 17, 2ª Planta. Oficina 3-2-15. Urb. Ind. El Sebadal – 35008 Las Palmas de Gran Canaria  
Tel: 928 24 45 80

<http://www.aguilera.es> e-mail: [comercial@aguilera.es](mailto:comercial@aguilera.es)